

System 330 (lay-on)	
Item	Description
1	Emac Hanger
2	C Profile Extrusion Bracket
3	C Profile
4	TCP 180 Slice
5	System 330 Lay-on Tile (25mm Deep)
6	Spring Pins
□	Distancing Profile



SAS International  
 31 Sultons Business Park  
 London Road, Reading  
 Berkshire RG6 1AZ  
 United Kingdom  
 Tel: +44 (0)118 929 0900  
 Fax: +44 (0)118 929 0901  
 www.sasint.co.uk

WORKNORM PATH  
 FOLDER SYSTEMS  
 FOLDER 330 AUS  
 FOLDER APPLICATION

REV DATE DESCRIPTION

SYSTEM 330 AUS  
 LINEAR SYSTEM ISOMETRIC

SCALE NOT TO SCALE DATE 23.03.16 DRAWN BY LB  
 DRG / ITEM No. 0391 REV  
 FACTORY BE/MB WORKNORM

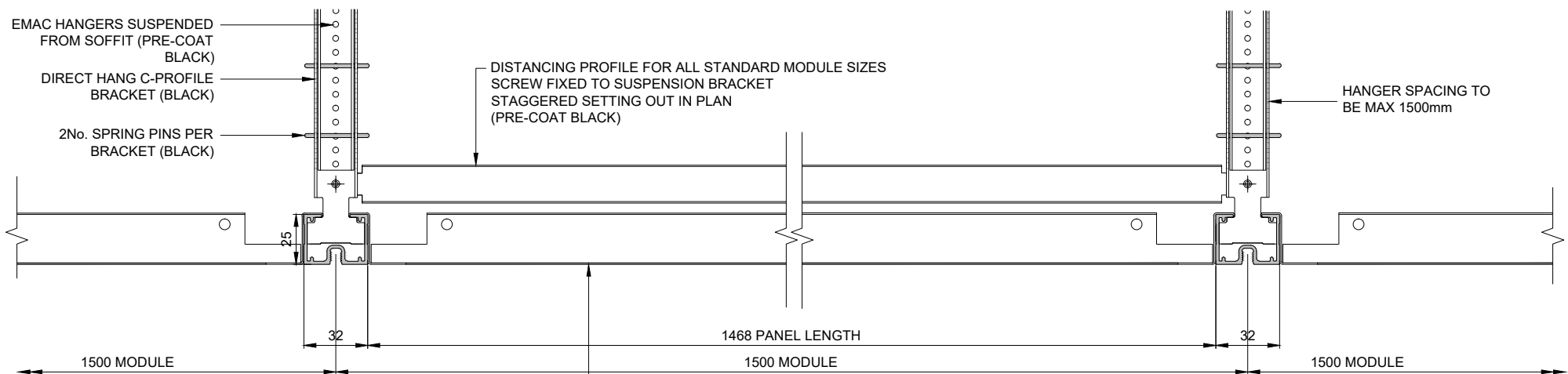

SECTION 'A'

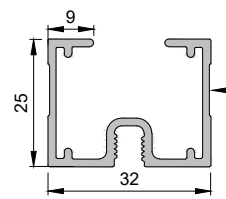

C-PROFILE SECTION

POLYESTER POWDER COATED PERFORATED PANELS. TYPICALLY SUPPLIED WITH BLACK ACOUSTIC FLEECE

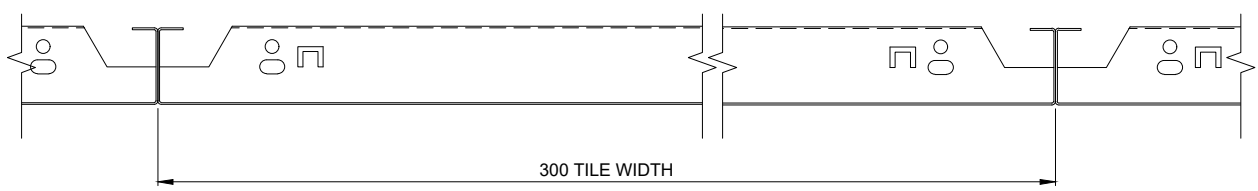

SECTION 'B'

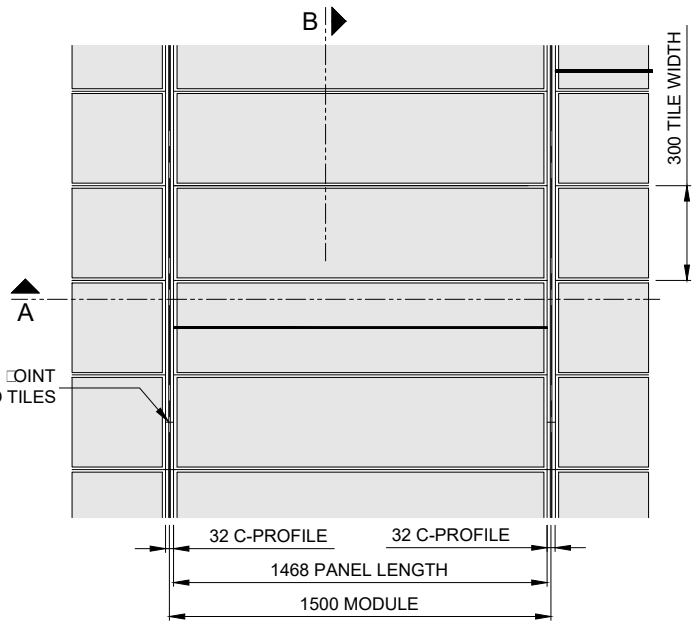

PART REFLECTED PLAN  
SCALE N.T.S.



SAS International  
31 Suttons Business Park  
London Road, Reading  
Berkshire RG6 1AZ  
United Kingdom  
Tel: +44 (0)118 929 0900  
Fax: +44 (0)118 929 0901  
www.sasint.co.uk

WORKNORM PATH	REV	DATE	DESCRIPTION
FOLDER SYSTEM			
FOLDER 330 AUS			
FOLDER APPLICATION			

SYSTEM 330 AUS  
TYPICAL LINEAR APPLICATION

SCALE	DATE	DRAWN BY
N.T.S	23.03.16	LB
DRG / ITEM No.	REV	
0393		A
FACTORY	WORKNORM	
BE / MB		

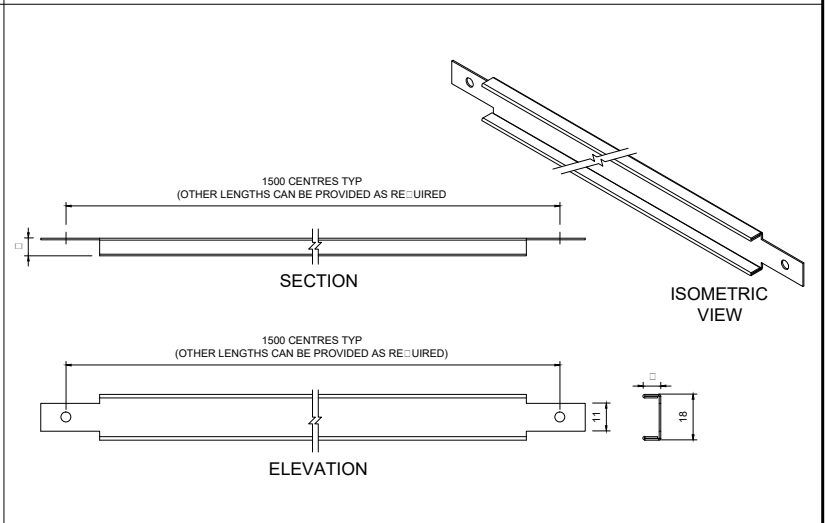
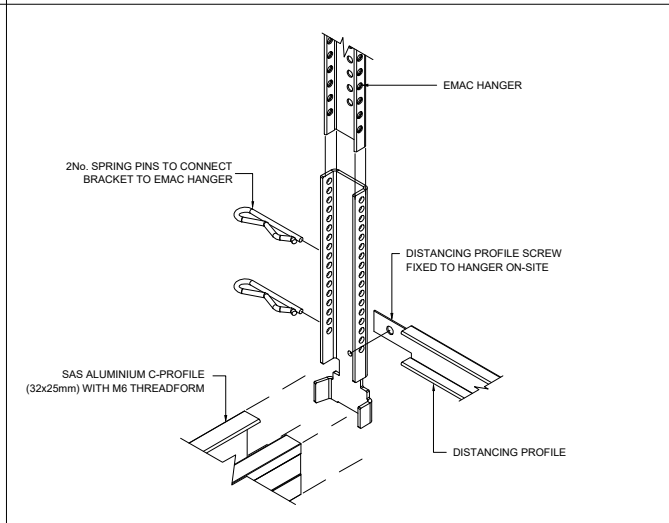
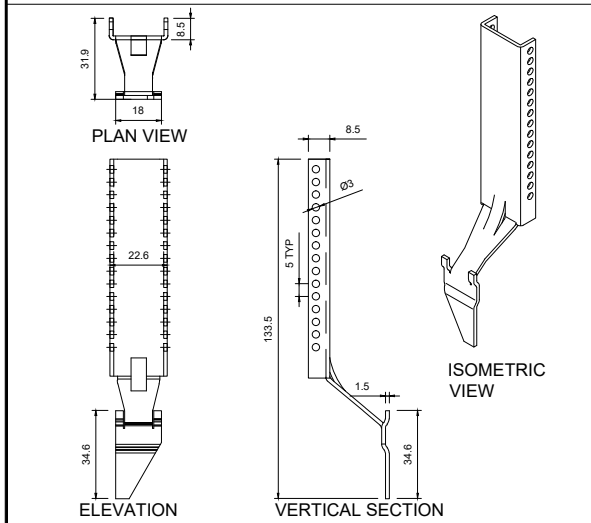
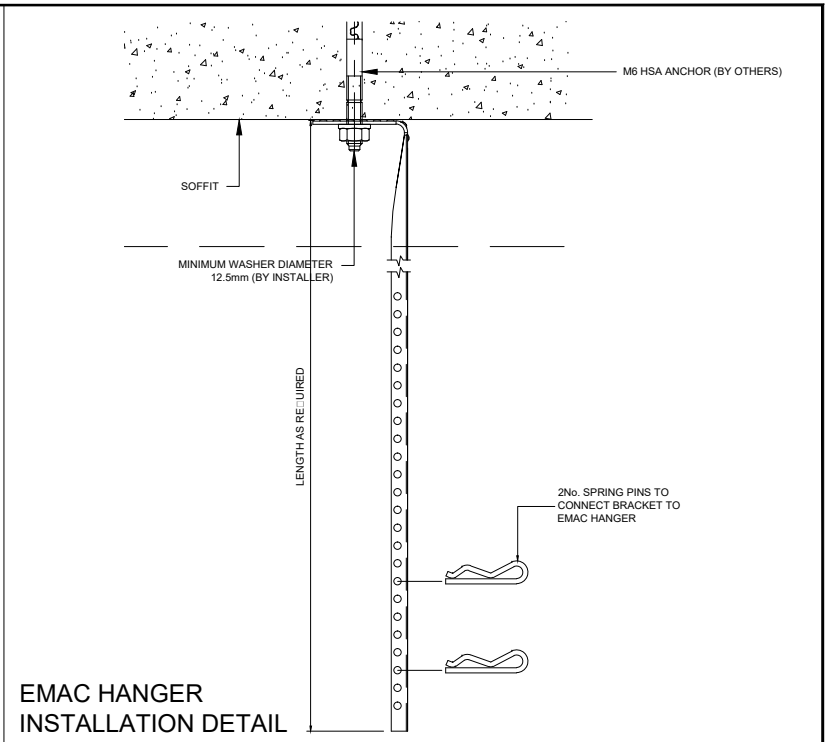
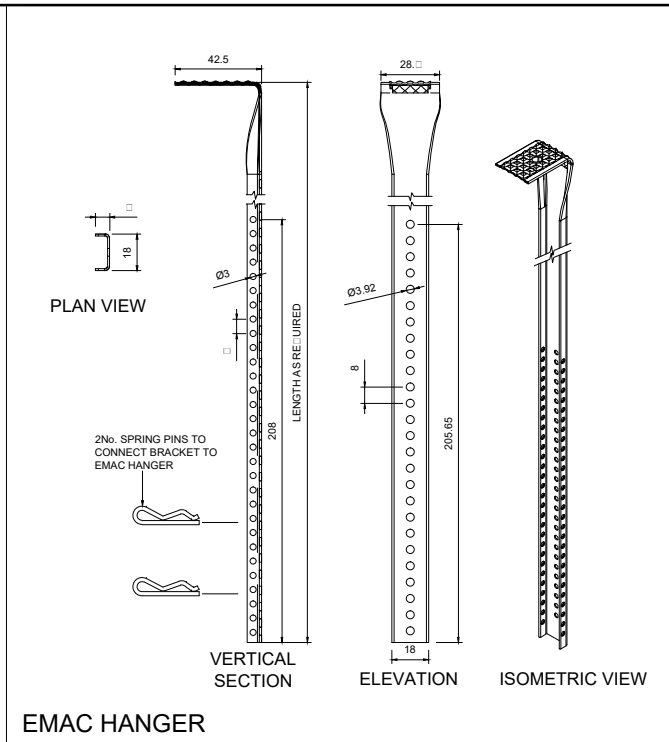
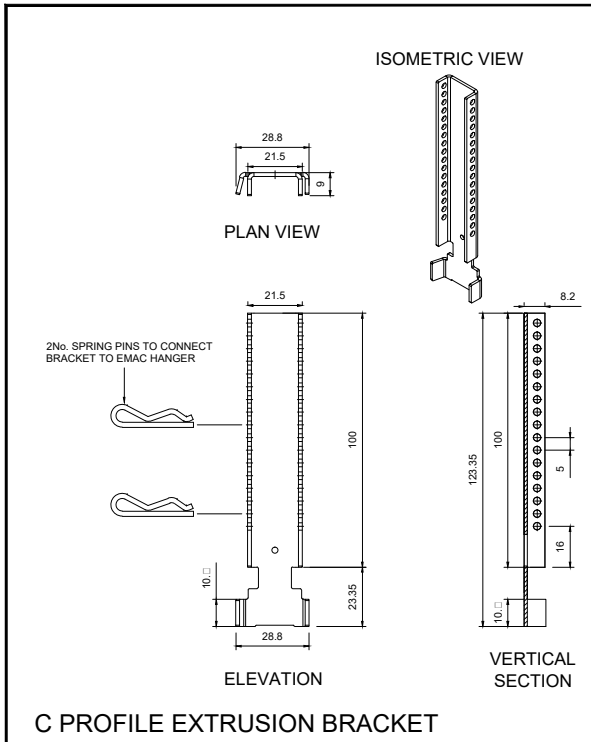

**TRIM TO HANGER BRACKET**

**SAS International**  
 31 Suttons Business Park  
 London Road, Reading  
 Berkshire RG6 1AZ  
 United Kingdom  
 Tel: +44 (0)118 929 0900  
 Fax: +44 (0)118 929 0901  
 www.sasint.co.uk

**WORKNORM PATH**  
 FOLDER SYSTEM  
 FOLDER 330 AUS  
 FOLDER APPLICATION

REV	DATE	DESCRIPTION

**SYSTEM 330 AUS**  
 TYPICAL LINEAR APPLICATION

SCALE	N.T.S	DATE	24.03.16	DRAWN BY	LB
DRG / ITEM No.	0392	REV			A
FACTORY	BE / AP				

**WORKNORM**

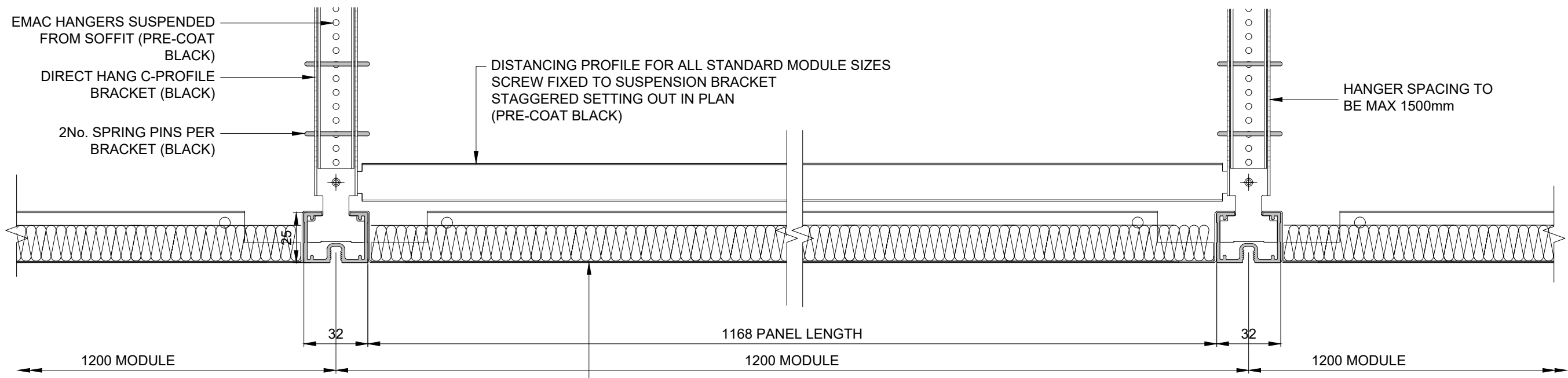

SECTION 'A'

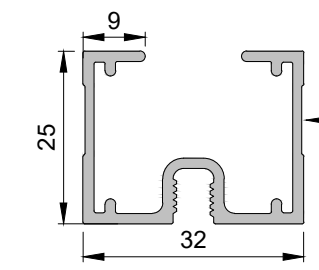

C-PROFILE SECTION

ALUMINIUM 32 x 25mm C PROFILE EXTRUSION WITH M6 CONTINUOUS THREAD

POLYESTER POWDER COATED PERFORATED PANELS. TYPICALLY SUPPLIED WITH BLACK ACOUSTIC PAD

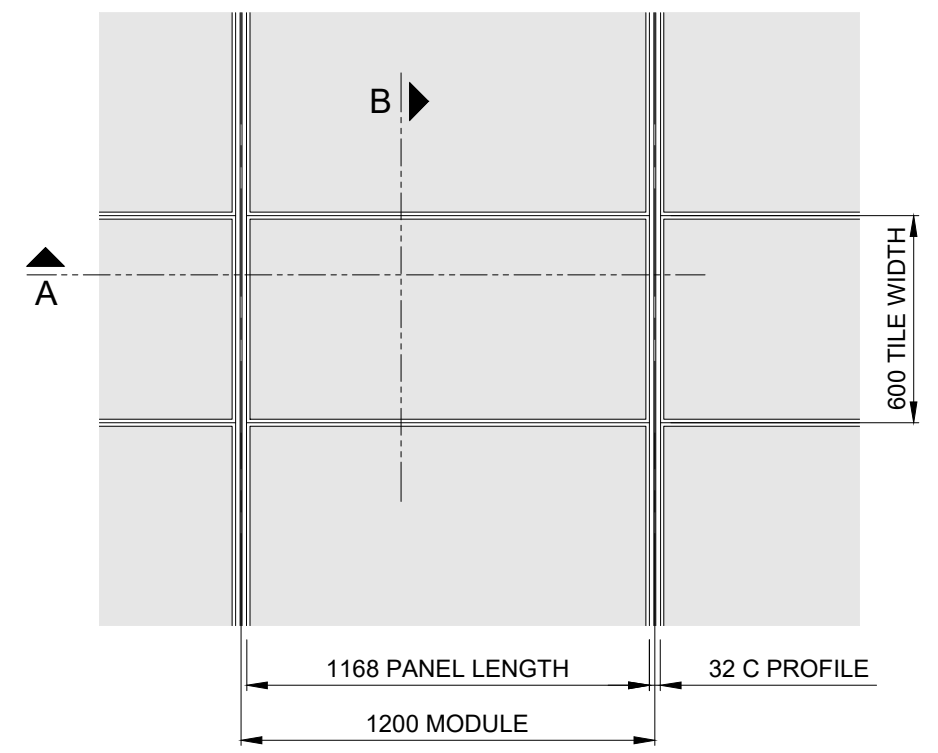

PART REFLECTED PLAN  
SCALE N.T.S.

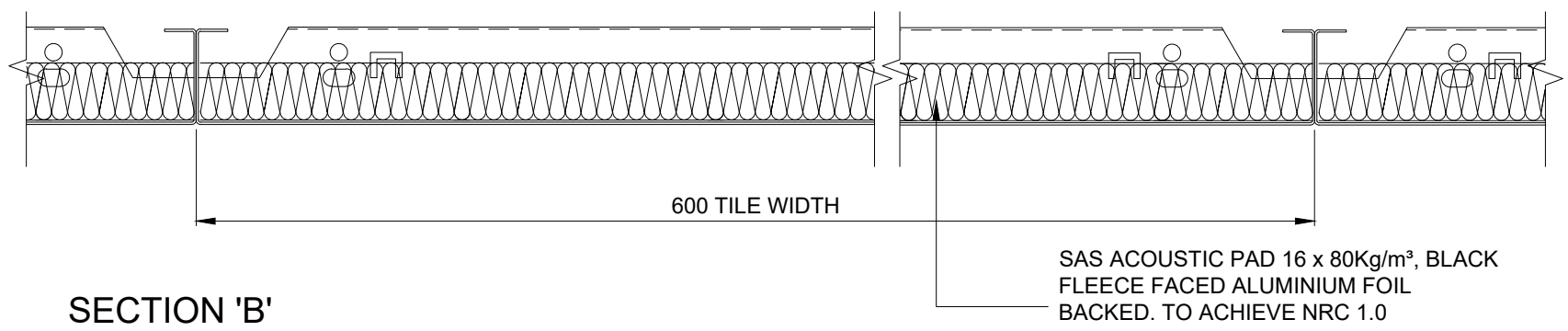

SECTION 'B'

SYSTEM 330 AUS  
TYPICAL LINEAR APPLICATION  
1200mm MODULE



SAS International  
31 Suttons Business Park  
London Road, Reading  
Berkshire RG6 1AZ  
United Kingdom  
Tel: +44 (0)118 929 0900  
Fax: +44 (0)118 929 0901  
www.sasint.co.uk

WORKNORM PATH	REV	DATE	DESCRIPTION
FOLDER SYSTEM			
FOLDER 330 AUS			
FOLDER APPLICATION			

SCALE	DATE	DRAWN BY
N.T.S	08.06.18	LB
DRG / ITEM No.	REV	
0393-1200		A
FACTORY	WORKNORM	
BE / MB		

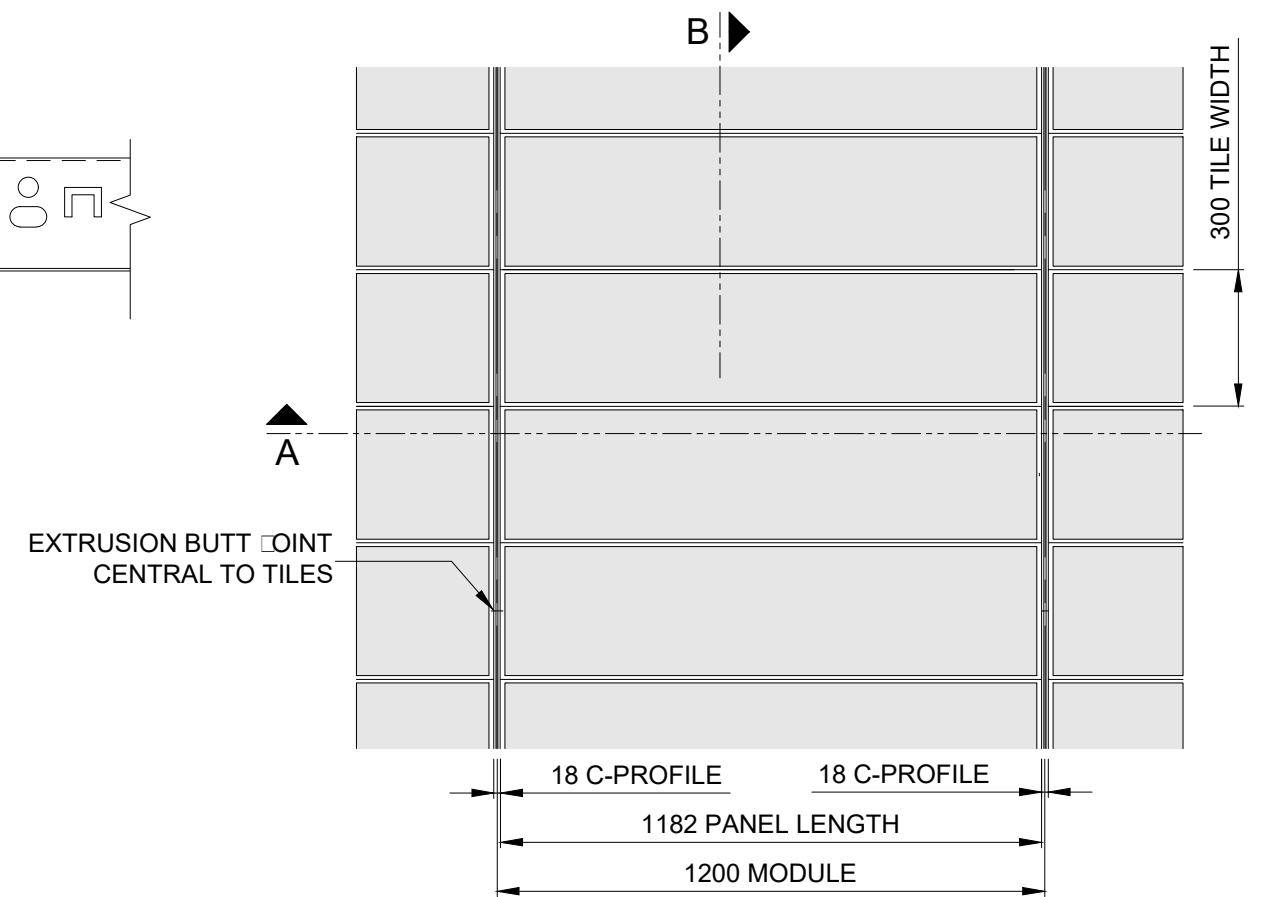
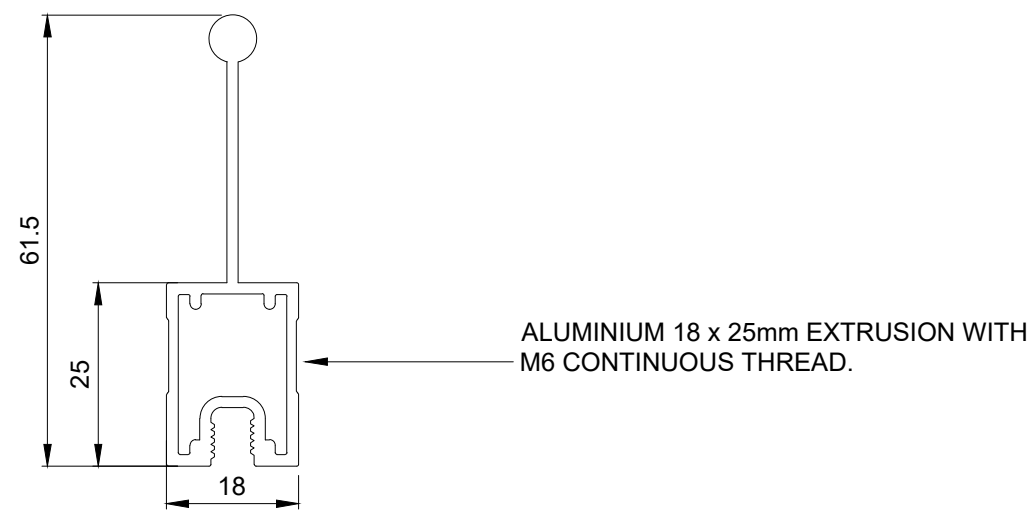
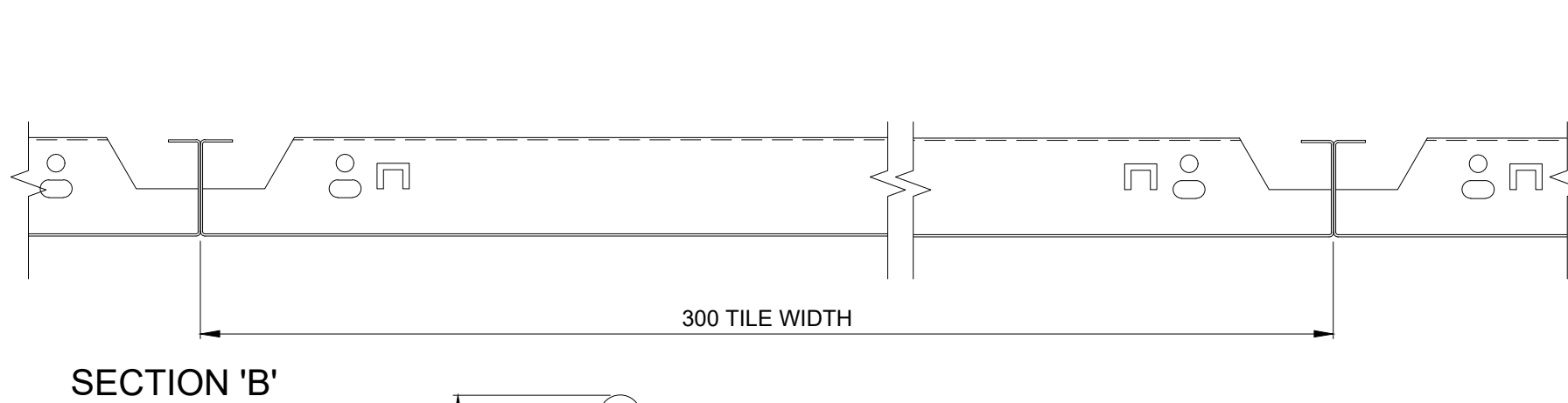
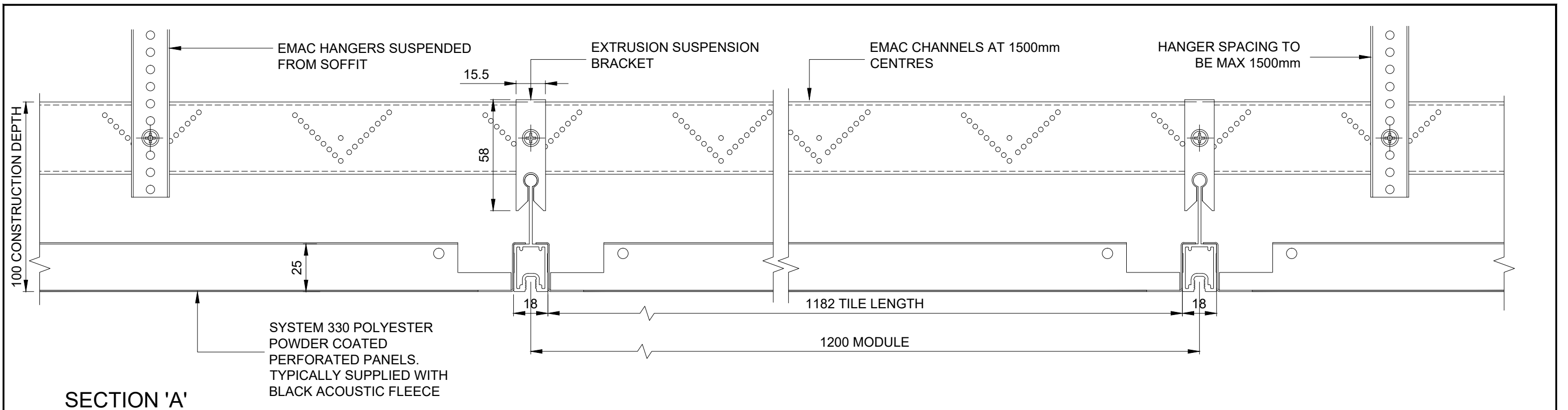

SAS International  
 31 Suttons Business Park  
 London Road, Reading  
 Berkshire RG6 1AZ  
 United Kingdom  
 Tel: +44 (0)118 929 0900  
 Fax: +44 (0)118 929 0901  
 www.sasint.co.uk

WORKNORM PATH	REV	DATE	DESCRIPTION
FOLDER SYSTEM			
FOLDER 330 AUS			
FOLDER APPLICATION			

SYSTEM 330 AUS SLIMLINE  
 TYPICAL LINEAR APPLICATION

SCALE	DATE	DRAWN BY
N.T.S.	23.03.16	LB
DRG / ITEM No.	REV	
0394		A
FACTORY	WORKNORM	
BE / MB		